



**Ningbo Haitian Precision Machinery Co., Ltd.**

**H.Q.& Production Base1**

No. 1688 Haitian road, Xiaogang, Beilun, Ningbo-315801, China.

Tel: +86-574-86182580/86182525

E-mail: [hision@mail.haitian.com](mailto:hision@mail.haitian.com)

**Production Base2**

No.235, Huangshan Road, Beilun District, Ningbo-315801 China.

**Production Base3**

No.188, Baodao Road, Lingang Industrial Zone, Changxing Island, Dalian-116317 China.

**Production Base4**

No.1 Haishun Road, Longjiang Town, Shunde District, Foshan-528303, China

**HUATENG MACHINERY (SINGAPORE) PTE. LTD.**

**Office Address:**

7 Temasek Boulevard #43-03A Singapore 038987

Website:

[www.haitianprecision.com](http://www.haitianprecision.com)

## CNC LATHE

TC II / TC Linear Guide / HTCMY / VTL

**HISON**

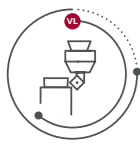

# PRODUCT INTRODUCTION

Haitian CNC Lathes are dedicated to delivering high rigidity, high-speed performance, ultra-precision, and exceptional stability. With a comprehensive product portfolio tailored to diverse user requirements, they are widely utilized in automotive components, general machinery parts, and related industries.



# CNC LATHE

- TC25 II \_\_\_\_\_ [Page 05]
- TC30 II \_\_\_\_\_ [Page 05]
- TC35A \_\_\_\_\_ [Page 06]
- TC40A \_\_\_\_\_ [Page 06]



- TG46 (Gang type lathe) \_\_\_\_\_ [Page 09]
- TC100 \_\_\_\_\_ [Page 09]
- TC150 \_\_\_\_\_ [Page 09]
- TC200 × 290 \_\_\_\_\_ [Page 10]
- TC200 × 520 \_\_\_\_\_ [Page 10]
- TC250 × 560 \_\_\_\_\_ [Page 10]



- HTC200MY \_\_\_\_\_ [Page 12]



- VTL125F \_\_\_\_\_ [Page 17]
- VTL160 \_\_\_\_\_ [Page 17]
- VTL200 \_\_\_\_\_ [Page 17]
- VTL250 \_\_\_\_\_ [Page 17]
- VTL350 \_\_\_\_\_ [Page 17]



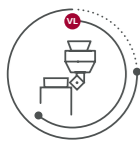

# TC / TC II

TC series CNC lathes adopt 45° integral casting bed structure and hardened grinding guide rail form. All castings are optimized by finite element analysis to ensure high precision and high stability of the machine tool. Perfect automatic interface, modular automatic protection design, for the rapid implementation of automation to provide a guarantee.

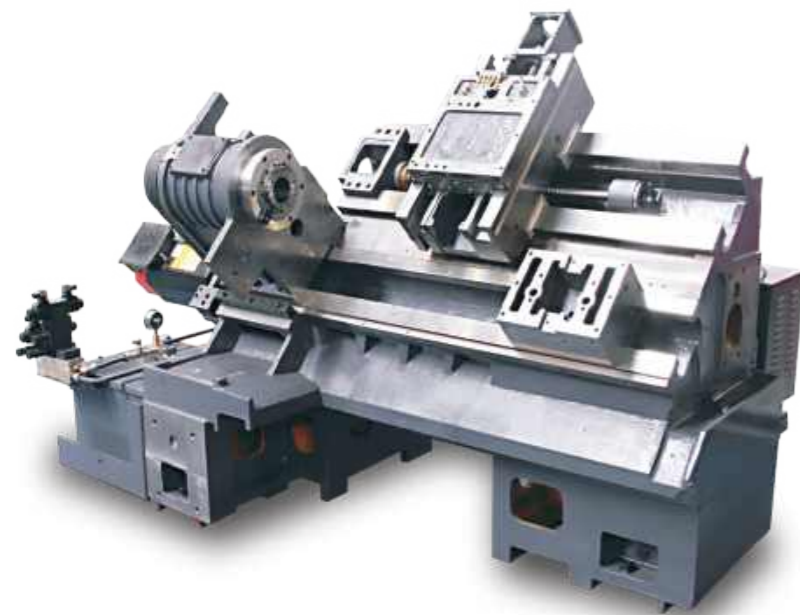

## 45° Integral Inclined Bed

The integral 45° inclined bed realizes the high rigidity, high stability and easy chip removal of the lathe. The guide rail has been hardened and finely ground, and wear-resistant soft belt is pasted on the sliding surface.



## High Rigidity Spindle

The whole series adopts imported bearings, two points support, front end adopts double row cylindrical roller bearings and high-speed thrust angular contact bearings, rear end adopts double row cylindrical roller bearings, strong rigidity, suitable for heavy cutting and precision cutting.

# TC / TC II



## Customized Cutter Head (Optional Power Turret)

TC series standard with 12 station hydraulic turret, suitable for heavy cutting. Customize the cutter head, so that the rigidity of the cutter block is strengthened and the tool interference area is small.

## Hydraulic Tailstock

Split tailstock structure, convenient and reliable adjustment; The whole movement of the tailstock is driven by the saddle; The telescopic sleeve is driven by hydraulic pressure and can be controlled programmatically.



## Automatic Protection Module

Automatic door, automatic skylight modular design, convenient installation.



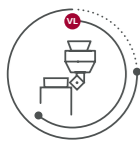

# TC II

Items	Unit	TC25 II × 500	TC25 II × 1000	TC30 II × 500	TC30 II × 1000	TC30 II × 1500
<b>» Machining Range</b>						
Max. swing over bed	mm	Φ560	Φ560	Φ650	Φ650	Φ650
Max. swing over saddle	mm	Φ320	Φ320	Φ420	Φ420	Φ420
Max. turning dia.	mm	Φ400	Φ400	Φ500	Φ500	Φ500
Max. turning length	mm	548	1000	500	1000	1490
Spindle center to ground	mm	980	980	1030	1030	1030
<b>» Spindle</b>						
Drive type	-	Belt	Belt	Belt	Belt	Belt
Max. spindle speed	rpm	4500	4500	3500	3500	3500
Spindle motor power (S1/S6)	kW	11/15	11/15	15/18.5	15/18.5	15/18.5
Spindle torque (S1/S6)	Nm	140/250	140/250	245/400	245/400	245/400
Spindle nose	-	A2-6	A2-6	A2-8	A2-8	A2-8
Spindle through-hole diameter	mm	Φ62	Φ62	Φ76	Φ76	Φ76
Spindle bearing diameter (Front)	mm	Φ100	Φ100	Φ120	Φ120	Φ120
Chuck size	inch	8	8	10	10	10
Bar capacity dia.	mm	Φ51	Φ51	Φ66	Φ66	Φ66
<b>» Turret</b>						
Type	-	Hydraulic	Hydraulic	Hydraulic	Hydraulic	Hydraulic
Turret capacity	-	12	12	12	12	12
OD tool size	mm	25×25	25×25	25×25	25×25	25×25
Max. boring bar size	mm	Φ40	Φ40	Φ40	Φ40	Φ40
Tool changing time (including clamp)	s	0.55	0.55	0.58	0.58	0.58
<b>» Tailstock</b>						
Tailstock type	-	Hydraulic	Hydraulic	Hydraulic	Hydraulic	Hydraulic
Tailstock travel	mm	410	730	410	730	1100
Quill dia.	mm	Φ100	Φ100	Φ100	Φ100	Φ100
Quill travel	mm	120	120	120	120	120
Quill bore taper	-	MT NO.4	MT NO.4	MT NO.5	MT NO.5	MT NO.5
<b>» Feed</b>						
X/Z axis travel	mm	210/610	210/1050	260/580	260/1050	260/1550
Rapid feed X/Z	m/min	24/30	24/30	16/20	16/20	16/20
Servo motor power X/Z	kW	1.8/1.8	1.8/1.8	2.5/2.5	2.5/2.5	2.5/2.5
Servo motor torque X/Z	Nm	11/11	11/11	20/20	20/20	20/20
<b>» Accuracy(GB/T16462.4-2007)</b>						
Positioning accuracy X/Z	mm	0.008/0.010	0.008/0.012	0.008/0.010	0.008/0.012	0.008/0.015
Repeat positioning accuracy X/Z	mm	0.005/0.006	0.005/0.008	0.005/0.006	0.005/0.008	0.005/0.010
<b>» Others</b>						
Power capacity	kVA	25	25	30	30	30
Coolant tank	L	200	250	200	250	300
Machine weight	t	4.5	5	4.9	5.4	6.3
Machine size (LxWxH) (without conveyor)	mm	4200×2050×1900	4600×2050×1900	4200×2050×2020	4600×2050×2020	5350×2050×2020

## Standard Configuration

1. Controller: FANUC 0i
2. Hydraulic and lubrication system
3. Cutting cooling
4. Full enclosure
5. 12T hydraulic turret station
6. Solid hydraulic chuck
7. Tool holder
8. Hydraulic tailstock with live center
9. External chain type chip conveyor (side)
10. Standard accessories
11. Flexible packaging
12. Ground installation
13. Common maintenance tools
14. Soft jaw
15. 3-color signal lamp, working light
16. Chuck foot switch
17. Trolley
18. CE Mark (EU region)

## Option Configuration

1. Controller: SIEMENS 828D
2. MC function (TC30 II)
3. Increase spindle bore
4. 2MPa coolant through spindle
5. 2/7MPa coolant through tool
6. Hollow chuck with hollow cylinder
7. External scrap type chip conveyor and trolley
8. Auto tool setter
9. Hydraulic tailstock
10. AC for electrical cabinet
11. Water gun
12. Air gun

# TC

Items	Unit	TC35A×1000	TC35A×1500	TC35A×2000	TC40A×1500	TC40A×2750
<b>» Machining Range</b>						
Max. swing over bed	mm	Φ700	Φ700	Φ700	Φ800	Φ800
Max. swing over saddle	mm	Φ600	Φ600	Φ600	Φ650	Φ650
Max. turning dia.	mm	Φ630	Φ630	Φ630	Φ800	Φ800
Max. turning length	mm	1000	1500	2000	1500	2750
Height of spindle center from ground	mm	1150	1150	1150	1200	1200
<b>» Spindle</b>						
Drive type	-	Belt	Belt	Belt	Belt	Belt
Max. spindle speed	rpm	2500	2500	2500	2000	2000
Spindle motor power (S1/S6)	kW	15/18.5	15/18.5	15/18.5	30/37	30/37
Spindle torque (S1/S6)	Nm	485/600	485/600	485/600	(L)2910/3574 (M)1134/1392 (H)453/557	(L)2910/3574 (M)1134/1392 (H)453/557
Spindle nose	-	A2-11	A2-11	A2-11	A2-11	A2-11
Spindle bore	mm	Φ102	Φ102	Φ102	Φ105	Φ105
Spindle bearing diameter (Front)	mm	Φ150	Φ150	Φ150	Φ170	Φ170
Chuck size	inch	12	12	12	15	15
Bar capacity dia.	mm	Φ89	Φ89	Φ89	Φ89	Φ89
<b>» Turret</b>						
Type	-	Hydraulic	Hydraulic	Hydraulic	Hydraulic	Hydraulic
Turret capacity	-	12	12	12	12	12
OD tool size	mm	32×32	32×32	32×32	32×32	32×32
Max. boring bar size	mm	Φ50	Φ50	Φ50	Φ60	Φ60
Tool changing time (including clamp)	s	0.65	0.65	0.65	0.85	0.85
<b>» Tailstock</b>						
Tailstock type	-	Hydraulic	Hydraulic	Hydraulic	Hydraulic	Hydraulic
Tailstock travel	mm	700	1200	1700	1100	2400
Quill dia.	mm	Φ130	Φ130	Φ130	Φ160	Φ160
Quill travel	mm	120	120	120	150	150
Quill bore taper	-	MT NO.5	MT NO.5	MT NO.5	MT NO.5	MT NO.5
<b>» Feed</b>						
X/Z axis travel	mm	345/1060	345/1560	345/2060	410/1570	410/2820
Rapid feed X/Z	m/min	16/20	16/20	16/16	12/12	12/12
Servo motor power X/Z	kW	3.0/3.0	3.0/3.0	3.0/3.0	4/7	4/7
Servo motor torque X/Z	Nm	20/20	20/20	20/20	22/30	22/30
<b>» Accuracy(GB/T16462.4-2007)</b>						
Positioning accuracy X/Z	mm	0.008/0.012	0.008/0.015	0.008/0.020	0.008/0.015	0.008/0.020
Repeat positioning accuracy X/Z	mm	0.005/0.008	0.005/0.010	0.005/0.012	0.005/0.010	0.005/0.012
<b>» Others</b>						
Power capacity	kVA	35	35	35	60	60
Coolant tank	L	250	290	330	270	350
Machine weight	t	9	10	11	12.5	14.5
Machine size (LxWxH) (without conveyor)	mm	5400×2200×2200	5800×2200×2200	6400×2350×2400	6450×2600×2400	7600×2850×2600

## Standard Configuration

1. Controller: FANUC 0i
2. Hydraulic and lubrication system
3. Cutting cooling
4. Full enclosure
5. 12T hydraulic turret station
6. Solid hydraulic chuck
7. Tool holder
8. Hydraulic tailstock
9. External chain type chip conveyor(side)
10. Standard accessories
11. Flexible packaging
12. Ground installation
13. Common maintenance tools
14. Soft jaw
15. 3-color signal lamp, working light
16. Foot switch with chuck tailstock
17. Trolley
18. CE Mark (EU region)

## Option Configuration

1. Controller: FANUC α3 (TC35A)
2. MC function (TC35A)
3. Increase spindle bore (TC35A)
4. 2MPa coolant through spindle (TC35A)
5. 2MPa coolant through tool
6. Hollow chuck with hollow cylinder
7. External scrap type chip conveyor and trolley
8. Auto tool setter
9. AC for electrical cabinet
10. Water gun
11. Air gun

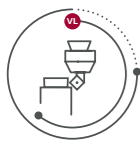

# TC LINEAR GUIDE SERIES

TC linear guide series adopts an integral casting bed structure,optimize parameters and internal structure,has a smaller footprint,Configure high-precision and high rigidity roller guides,mechanical spindle and servo turret,ensure high precision, efficiency, and stability of machine tools.

# TC LINEAR GUIDE SERIES

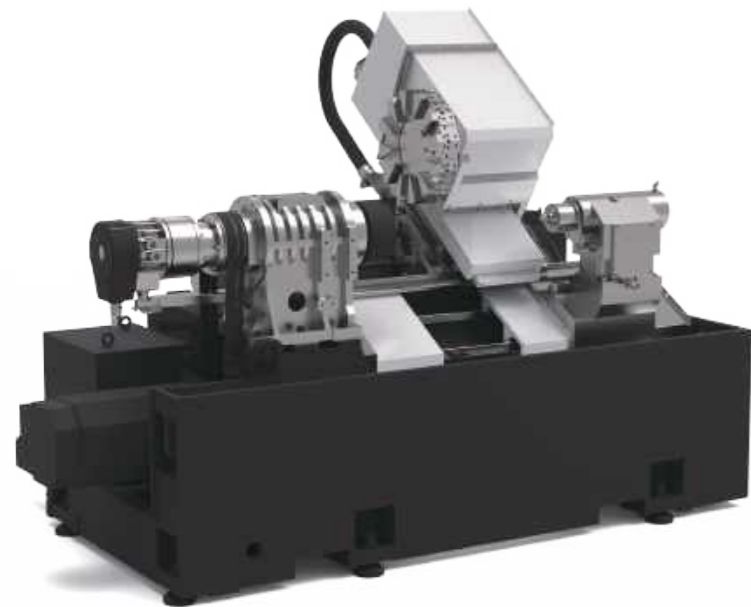

## Integrated inclined bed body

- intergrated bed body reduce center height ,improve machine rigidity;
- The main motor has been changed from outside the bed to inside the bed,effectively reducing footprint.

## High rigidity spindle

Large through-hole spindle, the entire series adopts imported bearings, two point support, strong rigidity, suitable for heavy cutting and precision cutting.



## Servo turret

- The entire series of lathes are equipped with servo turrets, turret rotation fast, reliable transmission link.
- The application of servo turret, realized synchronous tool change during the machine tool zeroing process, Improved production efficiency.

## Hydraulic tailstock

Stepped tailstock structure (embedded with steel), The overall movement of the tailstock is driven by the sliding saddle, The telescopic sleeve is hydraulically driven and programmable.



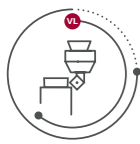

# TC LINEAR GUIDE SERIES

Items	Unit	TG46 (Gang type lathe)	TC100	TC150
<b>» Machining Range</b>				
Swing over bed dia.	mm	φ500	φ440	φ550
Swing over saddle	mm	-	φ220	φ340
Max. turning dia.	mm	φ430	φ220	φ300
Max. turning length	mm	300	200	300
Height of spindle center from ground	mm	1075	1025	1030
<b>» Turret</b>				
Turret type	-	-	Servo V8	Servo V12
OD tool size	mm	-	20×20	25×25
Max. boring bar dia.	mm	-	φ25	φ32
Indexing time	sec/step	-	0.2	0.2
<b>» Spindle</b>				
Drive type		Belt drive	Mechanical spindle	Mechanical spindle
Max. spindle speed	rpm	5000	6000	5000
Spindle motor power (S1/S6)	kW	5.5/7.5	5.5/7.5	7.5/11
Spindle torque (S1/S6)	Nm	40.4/73.4	40/74	57/112
Spindle nose	-	JISA2-5	JISA2-5	JISA2-5
Spindle through hole	mm	φ61	φ51	φ61
Spindle bearing diameter(Front)	mm	φ90	φ80	φ90
Chuck size	inch	-	6	6
Bar capacity dia.	mm	φ45	φ41 (Opt.φ31)	φ44 (Opt.φ51)
<b>» Tailstock</b>				
Quill dia.	mm	-	φ50 (Opt.)	φ70 (Opt.)
Quill taper	-	-	MT NO.4	MT NO.4
Quill travel	mm	-	95	90
Tailstock travel	mm	-	180	275
Tailstock type	-	-	-	-
<b>» Feed</b>				
Travel X/Z	mm	450/300	125/240	180/355
Rapid feed X/Z	m/min	33/36	30/30	33/36
Motor power X/Z	kW	1.5/1.0	1.2/1.2	1.8/1.8
Motor torque X/Z	Nm	9/5.9	7/7	11/11
<b>» Drive</b>				
Servo motor power	kW	1.5/1.0	1.2/1.2	1.8/1.8
<b>» Accuracy (GB/T16462.4—2007)</b>				
Positioning accuracy X/Z	mm	0.008	0.008	0.008
Repeat positioning accuracy X/Z	mm	0.005	0.005	0.005
<b>» Others</b>				
Power capacity	kVA	15	15	20
Coolant tank	L	100	140	180
Machine weight	t	-	2	3.7
Machine size(LxWxH) (without conveyor)	mm	2140×1510×1800	1570×1460×1610	2120×1740×1750

## Standard Configuration

1. Controller: FANUC 0i β5 (TG46 with Mitsubishi)
2. Servo turret
3. Solid chuck (TC100 with hollow chuck, TG46 with collet)
4. Chuck foot switch
5. Full enclosure
6. Cutting cooling
7. Tool holder
8. Safty door lock
9. Soft jaw (Except TG46)
10. Manual chip box
11. 3-color signal light, working light
12. Standard accessories
13. Common maintenance tool
14. CE Mark (EU region)

## Option Configuration

1. Controller: SIEMENS 828D
2. MC function(TC150)
3. 2MPa coolant through spindle
4. 2/7MPa coolant through tool
5. Hollow chuck with hollow cylinder
6. External chain type chip conveyor and trolley(TC150)
7. Auto tool setter
8. Hydraulic tailstock
9. AC for electrical cabinet
10. Water gun
11. Air gun

# TC LINEAR GUIDE SERIES

Items	Unit	TC200×290	TC200×520	TC250×560
<b>» Machining Range</b>				
Swing over bed dia.	mm	φ550	φ550	φ620
Swing over saddle	mm	φ340	φ340	φ410
Max. turning dia.	mm	φ330	φ330	φ420
Max. turning length	mm	290	520	560
Height of spindle center from ground	mm	1030	1030	1035
<b>» Turret</b>				
Turret type	-	Servo V12	Servo V12	Servo V12
OD tool size	mm	25×25	25×25	25×25
Max. boring bar dia.	mm	φ40	φ40	φ40
Indexing time	sec/step	0.2	0.2	0.2
<b>» Spindle</b>				
Drive type		Mechanical spindle	Mechanical spindle	Mechanical spindle
Max. spindle speed	rpm	4500	4500	3500
Spindle motor power (S1/S6)	kW	11/15	11/15	15/18.5
Spindle torque (S1/S6)	Nm	140/255	140/255	248/409
Spindle nose	-	JISA2-6	JISA2-6	JISA2-8
Spindle through hole	mm	φ66	φ66	φ81
Spindle bearing diameter (Front)	mm	φ100	φ100	φ120
Chuck size	inch	8	8	10
Bar capacity dia.	mm	φ51 (Opt.φ65)	φ51 (Opt.φ65)	φ71
<b>» Tailstock</b>				
Quill dia.	mm	φ70 (Opt.)	φ100	φ100
Quill taper	-	MT NO.4	MT NO.4	MT NO.5
Quill travel	mm	90/120	120	120
Tailstock travel	mm	275	442	520
Tailstock type	-	-	Hydraulic	Hydraulic
<b>» Feed</b>				
Travel X/Z	mm	204/357	204/590	225/615
Rapid feed X/Z	m/min	33/36	33/36	30/36
Motor power X/Z	kW	1.8/1.8	1.8/1.8	3.0/3.0
Motor torque X/Z	Nm	11/11	11/11	20/20
<b>» Drive</b>				
Servo motor power	kW	1.8/1.8	1.8/1.8	3.0/3.0
<b>» Accuracy (GB/T16462.4—2007)</b>				
Positioning accuracy X/Z	mm	0.008	0.008/0.010	0.008/0.010
Repeat positioning accuracy X/Z	mm	0.005	0.005	0.005
<b>» Others</b>				
Power capacity	kVA	25	25	30
Coolant tank	L	180	220	210
Machine weight	t	3.8	4.2	5.2
Machine size (LxWxH) (without conveyor)	mm	2180×1740×1750	2510×1850×1750	3260×1900×1770

## Standard Configuration

1. Controller: FANUC 0i β5
2. Servo turret
3. Solid chuck
4. Chuck foot switch
5. Full enclosure
6. Cutting cooling
7. Tool holder
8. Safty door lock
9. Soft jaw
10. Manual chip box (Except TC250)
11. External chain type chip conveyor (Rear middle) (TC250)
12. Hydraulic tailstock (Only TC200×520 and TC250×560)
13. 3-color signal light, working light
14. Standard accessories
15. Common maintenance tool
16. CE Mark (EU region)

## Option Configuration

1. Controller: SIEMENS 828D
2. MC function
3. Increase spindle bore(TC200)
4. 2MPa coolant through spindle
5. 2/7MPa coolant through tool
6. Hollow chuck with hollow cylinder
7. External chain type chip conveyor and trolley
8. Auto tool setter
9. Hydraulic tailstock
10. AC for electrical cabinet
11. Water gun
12. Air gun

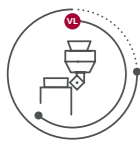

# MY SERIES CNC LATHE

HTC200MY is a CNC lathe equipped with a Y-axis and power turret, designed with the core principles of high efficiency, precision, and reliability. The machine integrates high-accuracy and rigid ball screws, a high-stiffness motorized spindle, and a servo-driven turret. Its design emphasizes environmental protection, energy efficiency, and ergonomic operation, making it widely suited for machining complex components across industries.



# HTC200MY

Items	Unit	HTC200MY
<b>» Machining Range</b>		
Max. swing over bed	mm	φ650
Max. swing over saddle	mm	φ440
Max. turning dia.	mm	φ350
Max. turning length	mm	530
Spindle center to ground	mm	1038
X axis travel	mm	228
Y axis travel	mm	±55
Z axis travel	mm	623
<b>» Turret</b>		
Type	-	BMT55
Turret capacity	mm	25×25
Max. boring bar size	mm	φ40
Tool changing time (including clamp)	s	0.3
<b>» Spindle</b>		
Drive type	-	Built-in spindle
Max. spindle speed	rpm	4500
Spindle motor power (S1/S6)	kW	11/15
Spindle nose	-	JISA2-6
Spindle through hole	mm	φ76
Chuck size	inch	8
Max. rigid tapping dia. of milling spindle	mm	M18×1.5
Max. tool overhang of milling spindle	mm	60
Motor power of milling spindle	kW	3.7/5.5
Milling spindle torque (S1/S6)	N.m	17.7/35
Max. milling spindle speed	rpm	4000
<b>» Feed</b>		
Rapid feed X/Y/Z	m/min	24/10/30
Servo motor power X/Y/Z	kW	1.8/1.8/1.8
<b>» Tailstock</b>		
Quill dia.	mm	φ100
Quill bore taper	-	MT NO.5
Quill travel	mm	120
Tailstock travel	mm	570
<b>» Accuracy (GB/T16462.4-2007)</b>		
Positioning accuracy X/Y/Z	mm	0.008/0.008/0.010
Repeat positioning accuracy X/Y/Z	mm	0.005
<b>» Others</b>		
Controller	-	FANUC Oi-TF
Power capacity	kVA	30
Coolant tank	L	200
Machine size (L×W×H)(without conveyor)	mm	3160×1930×2140

## Standard Configuration

1. Controller: FANUC Oi
2. Hydraulic, lubrication and cooling system
3. Servo turret
4. Solid hydraulic chuck
5. Tool holder
6. Hydraulic tailstock
7. Live tip
8. Soft jaw
9. 3-color signal light, working light
10. Transformer
11. Buzzer
12. Safety door lock
13. Footplate
14. Chuck foot switch
15. External chain type chip conveyor and trolley
16. Standard accessories
17. Common maintenance tool
18. CE Mark (EU region)

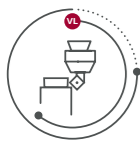

# CNC VERTICAL LATHE

Technology from the Canadian company Philips-Olympia, first-line products in European and American markets, Chinese Haitian Precision aims to contribute to the improvement of China's machinery manufacturing industry.

Known for its high rigidity, high speed, high precision and high cutting force in the European and American markets, under the premise of meeting the turning function, the C-axis and the second spindle with excellent dynamic characteristics can achieve continuous composite cutting and high-precision indexing processing, supplemented by a variety of functional accessories, including grinding functions, to provide users with excellent solutions for complex shape parts.

# CNC VERTICAL LATHE

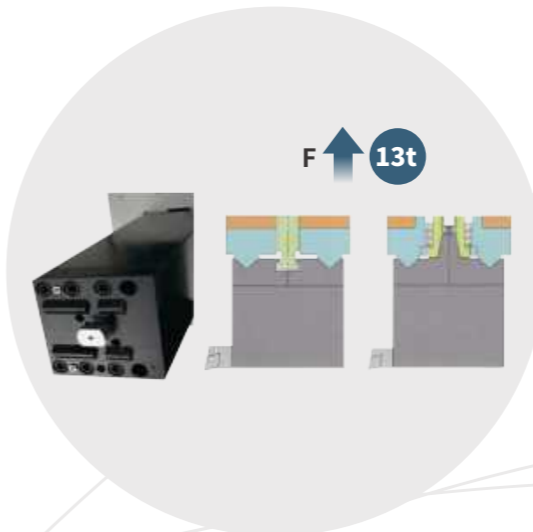

## Unique V-shaped cutter block positioning clamping system

- The tool clamping force of 13t connects the tool holder to the ram. The double V-shaped clamping device provides a wide and powerful clamping surface. The short V-shaped positioning contact surface minimizes the possibility of surface chips.

## High precision and high performance dual motor (optional)

- The use of dual motor anti-backlash structure, can achieve high precision C-axis indexing, more suitable for high-end market demand.

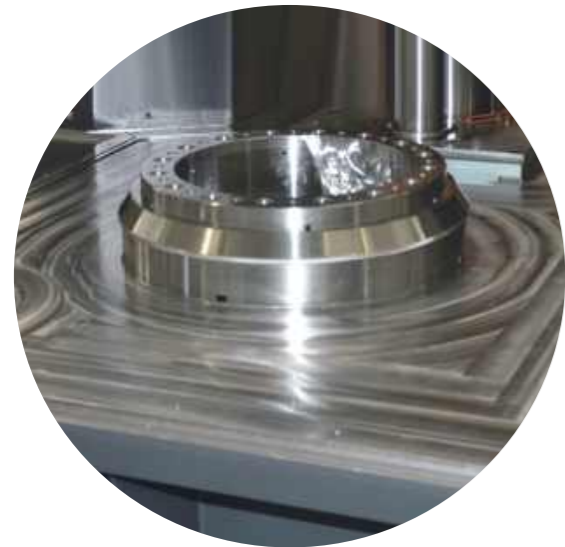

## Characteristics of large cross tapered roller combination bearing

- Low center of gravity, small centrifugal force
- Teflon bearing retainer, small inertia, can operate at low torque force
- High rigidity, high precision, vibration resistance, easy lubrication
- Uniform heat conduction, low wear, long life



## Tin bronze guide pair

- Unique wide contact tin bronze sliding guide, it is far greater than the contact stiffness of plastered or injection molded guides
- To achieve long-term stable accuracy and better damping effect



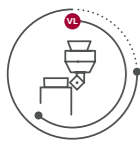

# CNC VERTICAL LATHE

# CNC VERTICAL LATHE



### Spindle motor drive system

- The main motor is connected to a two-speed gearbox or a three-speed gear transmission, which drives the pinion to drag the big gear ring to achieve high horsepower and high torque output.

### Constant temperature oil cooling system

- The use of fluoride-free environment-friendly constant temperature system avoids the adverse effects of spindle thermal deformation on parts processing.

### Automatic chip conveyor

- The new 45° chain-plate automatic chip conveyor is stable, reliable, smooth and clean.

### Milling spindle unit (optional)

- The two-speed gear shift provides the low speed and high torque required for heavy cutting, while also providing the ability to finish surfaces at high speeds.

### Beam lifting system

- By controlling the motor to drive the reducer, the worm wheel screw lift can effectively drive the beam to move up and down, and the ladder latch is used to achieve multi-point positioning, and the out-of-tolerance protection mechanism is provided, which is reliable, safe and accurate.

### Tool magazine unit

- Optional 12/16/24 turning tool or milling cutter magazine, smooth action, fast tool change, high efficiency.

### Workbench components

- High strength and high quality cast iron bed, equipped with large cross tapered roller combination bearing, small occupation space, low center of gravity, small centrifugal force, uniform heat conduction, combined with precision cooling control system, small thermal deformation, high rotation speed.

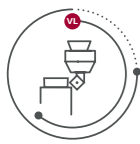

# CNC VERTICAL LATHE

Items	Unit	VTL125F	VTL160	VTL200	VTL250	VTL350
<b>» Main Parameter</b>						
Table dia.	mm	Φ1000	Φ1250	Φ1600	Φ2000	Φ3000
Max. rotating dia.	mm	Φ1250	Φ1600	Φ2000	Φ2500	Φ3500
Max. turning dia.	mm	Φ1250	Φ1600	Φ2000	Φ2500	Φ3500
Max. turning height	mm	800	1200/1800	1200/1800	1600/2000	2000/2500
<b>» Stroke Parameter</b>						
X travel	mm	-50/+780	-100/+960	-100/1150	-100/+1400	-100/+1900
Z travel	mm	800	1000	1000	1500	1500
Cross beam travel	mm	Fixed beam	800/1200	800/1200	1200/1600	1200/1700
<b>» Table</b>						
Table load	t	4	5	8	10	20
Max. rotation speed	rpm	600	350	250	200	120
Max. torque	N.m	10380	14805	19487	55642	63727
<b>» Feed</b>						
X-axis rapid feedrate	m/min	10	10	10	10	10
Z-axis rapid feedrate	m/min	10	10	10	10	10
Max. cutting feedrate	mm/min	1-2000	1-2000	1-2000	1-2000	1-2000
<b>» Power Parameters</b>						
Servo motor power	kW	37/45	37/45	37/45	60/75	60/75
<b>» Tool Magazine</b>						
Tool magazine capacity	T	12	12	12	12	12
Max. tool length	mm	400	400	400	400	400
Max. tool weight	kg	50	50	50	50	50
<b>» Accuracy</b>						
Positioning accuracy X/Z	mm	0.025/0.025	0.025/0.025	0.032/0.025	0.032/0.032	0.032/0.032
Repeat positioning accuracy X/Z	mm	0.01/0.01	0.01/0.01	0.013/0.01	0.013/0.013	0.013/0.013
Table runout	mm	0.01 (per 1000)	0.01 (per 1000)	0.01 (per 1000)	0.01 (per 1000)	0.01 (per 1000)
<b>» Others</b>						
Power capacity	kVA	80	90	90	120	120
Machine weight	t	22	35	40	50	65
Machine size (L×W×H)	mm	5600×4000×5000	6000×4500×5500	6300×4750×5500	7000×5100×7200	7550×5700×7200

## Standard Configuration

1. Controller: FANUC 0i
2. Four-jaw manual chuck
3. Standard length rams
4. Spindle variable speed gearbox
5. Pneumatic, hydraulic, centralized lubrication system
6. Cutting cooling
7. External chain type chip conveyor
8. Electric cabinet heat exchanger
9. Standard turning tool holder(2pcs)
10. Enclosure without top
11. Security door locks
12. 3-color signal lamp, working light
13. Common maintenance tool
14. Hand pulse generator
15. 12T tool magazine
16. CE Mark (EU region)

## Option Configuration

1. SIEMENS 828D
2. Tool setter
3. X/Z linear scale
4. Automatic hydraulic chuck
5. Workpiece probe
6. Paper bag filter
7. Oil skimmer
8. Coolant through the tools
9. AC for electric cabinet
10. Transformer
11. Customized tools

## Power Torque Diagram

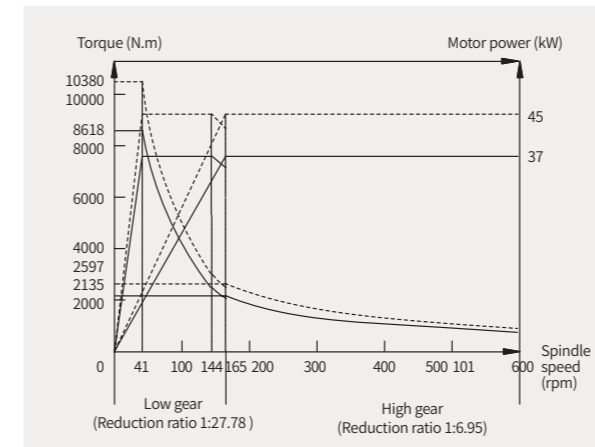

VTL125F

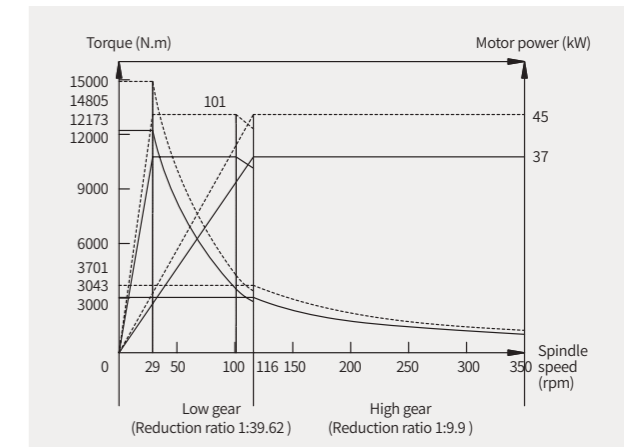

VTL160

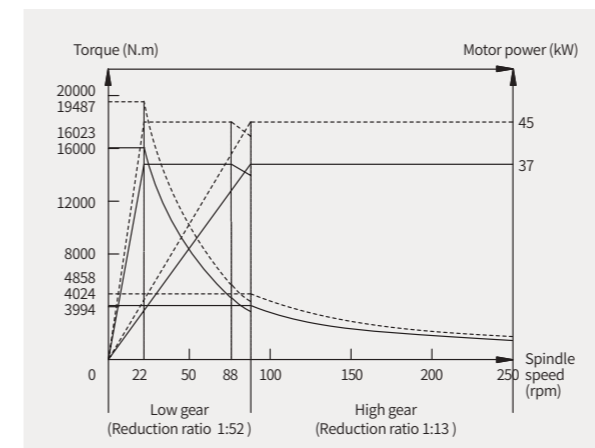

VTL200

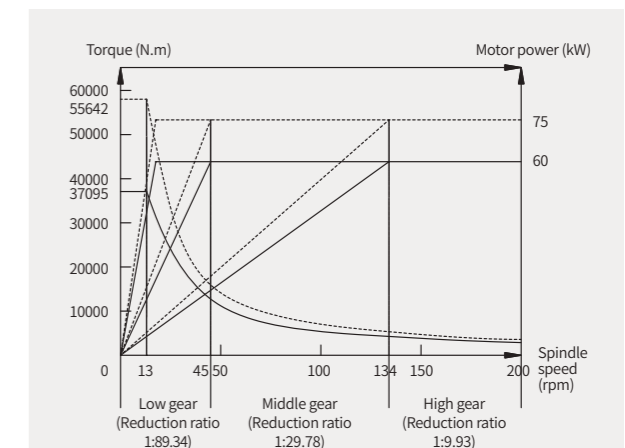

VTL250

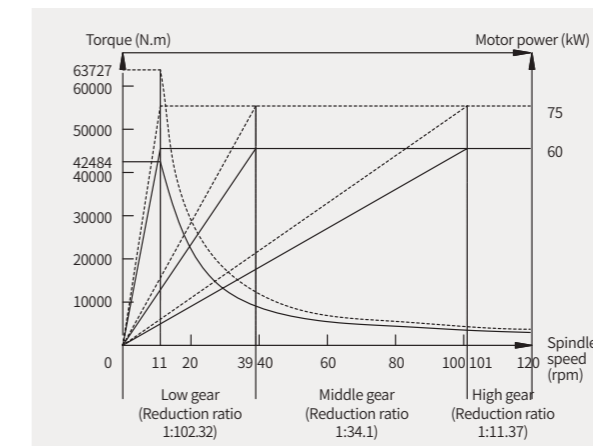

VTL350

(Solid line indicates the continuous processing, dashed line indicates the 30-minute processing.)